



4891 INDEPENDENCE STREET
Wheat Ridge, Colorado 80033

CALL TO SCHEDULE A VIRTUAL TOUR



PROPERTY FEATURES

- Ready to Rent Condition
- Close Proximity to Retail Amenities
- Excellent Access and Visibility to I-70
- Proximity to Downtown & Mountain Communities
- Abundant Parking Available
- On Site Management

BUILDING SPECIFICATIONS

Building Area:	44,796 SF
Number of Stories:	Two
Year Built:	1984
Typical Floorplate:	22,398 SF
Parking:	4/1,000 SF
Available Suites:	423 - 3,019 RSF
Access:	I-70 West / Kipling St.
Lease Rates:	\$18.00 - \$18.50 FSG

FOR MORE INFORMATION CONTACT:

TIM P. ROGERS

tprogers@gcgcre.com | 720.476.5225

C. JAMIE MACBETH

jmacbeth@gcgcre.com | 720.476.5229

T. BLAKE ROGERS

tblakerogers@gcgcre.com | 720.530.5788

AVAILABILITY

SUITE #	SIZE	DESCRIPTION
170	423 RSF	One Private Office, Reception and Storage
230	685 RSF	One Private, Reception, Open Area
200	1,538 RSF	Reception, 6 Privates (5 on Glass), Conference Room, Storage Room
125	2,114 RSF	5 Privates on Glass, Break Room, Open Area, Reception
285	1,840 RSF	4 Privates (3 on Glass), Conference Room, Break Room, Open Area, Storage Room

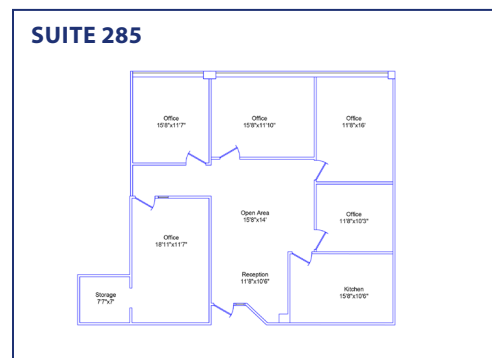
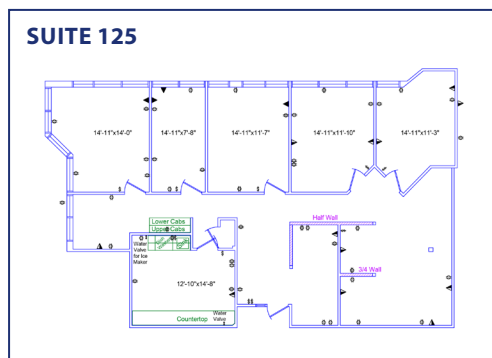
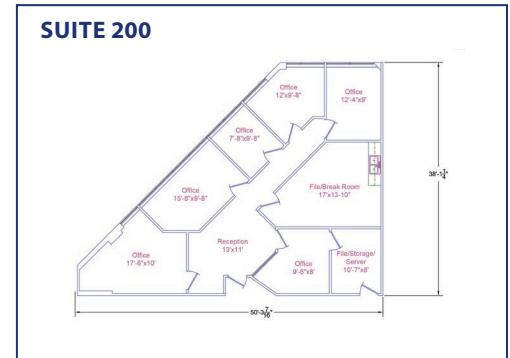
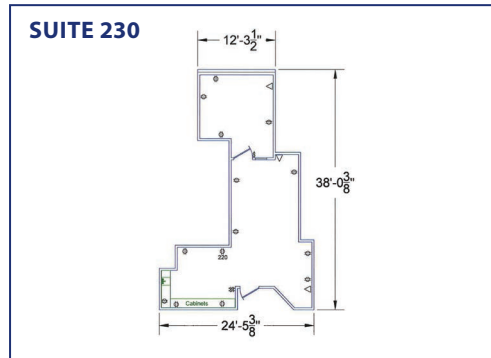
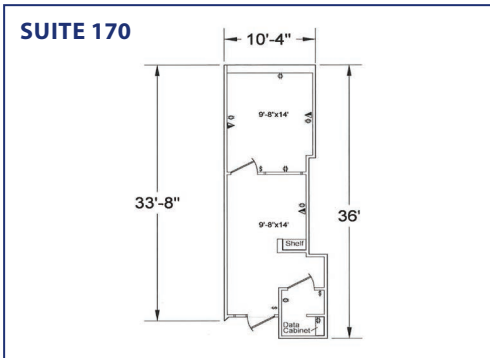

No warranty or representation is made as to the accuracy of the foregoing information. Terms of sale or lease and availability are subject to change or withdrawal without notice.

FOR MORE INFORMATION CONTACT:

TIM P. ROGERS

tprogers@gcgcre.com | 720.476.5225

C. JAMIE MACBETH

jmacbeth@gcgcre.com | 720.476.5229

T. BLAKE ROGERS

tblakerogers@gcgcre.com | 720.530.5788